

Model SCB All-Purpose Severe Service Choke

The Model SCB is a forged body, all-purpose severe service choke, available as an Adjustable or a Positive model.

Features:

Adjustable Choke

- Worm gear drive actuator – eliminates backlash and provides precise control; self-locking to prevent movement even if hydraulic pressure is lost.
- Quick change actuator – no need to disconnect hoses for removal. Trim can be changed in 15 minutes or less without removing the choke from the line or breaking into the manifold.
- Accommodates 1-1/2", 2" or 3" trim size
- Manual override capability - provided on all worm gear-operated hydraulic chokes in case of power loss.
- Other types of actuator available – in addition to the exclusive modified worm gear actuator, our chokes are available with hydraulic piston, electric or manual actuators.
- Reversible gate and seat assembly – provides a minimum of two uses per piece, saving parts, reducing operating costs and maximizing efficiency. Can be reversed in the field.
- Solid tungsten carbide gate and seat – proven design provides maximum erosion resistance. Gate and seat are precision-ground to provide drop tight shutoff.

Positive Choke (except Model SCC)

- Quick change bean – bonnet easily removable. Service tools available to remove bean and bean carrier quickly for inspection or replacement.
- Numerous bean sizes – accepts 1" (64/64ths) maximum orifice H2-style or OCT-style bean, or a 3" solid tungsten carbide bean seat (192/64ths).

All Chokes

- Pressure balanced trim – reduces operating forces, whether the choke is operated manually or automatically. Large balance ports provide protection against clogging.
- Downstream wear sleeve and retainer ring – extended-length solid tungsten carbide seat provides wear protection downstream and a smooth transition for fluid into the downstream piping.
- Large buffer cavity – slows velocity and distributes impact of solids, maximizing trim life.

Actuator Manipulator Option

- Allows one-man, in-line servicing of chokes
- No lifting device required
- 15-minute service time

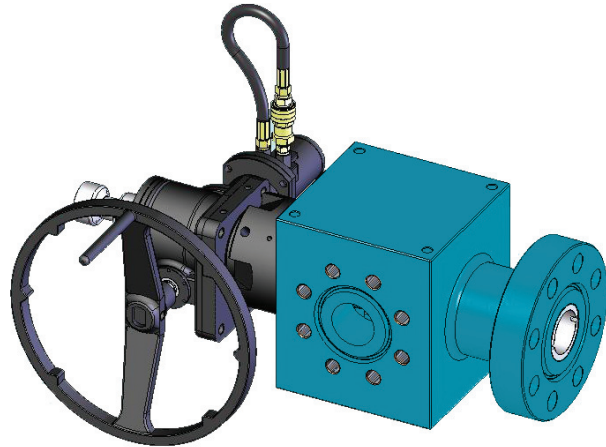

Model SCB Choke with Hydraulic Actuator and Manual Override

Control Consoles

- Offer operation for one, two or more chokes and / or hydraulic control valves
- Speed adjusts to allow fast or slow choke movement
- One or two hydraulic pumps plus manual backup hydraulic pump
- Bourdon tube hydraulic pressure gauges or digital pressures gauges available
- Digital position indicator gauge standard
- Accumulators available for power backup or to smooth choke operation

Both Adjustable and Positive Chokes supplied with:

- Bleeder port to bleed pressure from choke body prior to choke bonnet removal for inspection or maintenance.
- Studded inlet X flanged outlet standard. Flanged inlets available.
- 3-1/16" inlet X 4-1/16" outlet standard for use in API 5M, 10M or 15M service.
- Other inlet and outlet sizes available.

Model SCB All-Purpose Severe Service Choke

Technical Data:

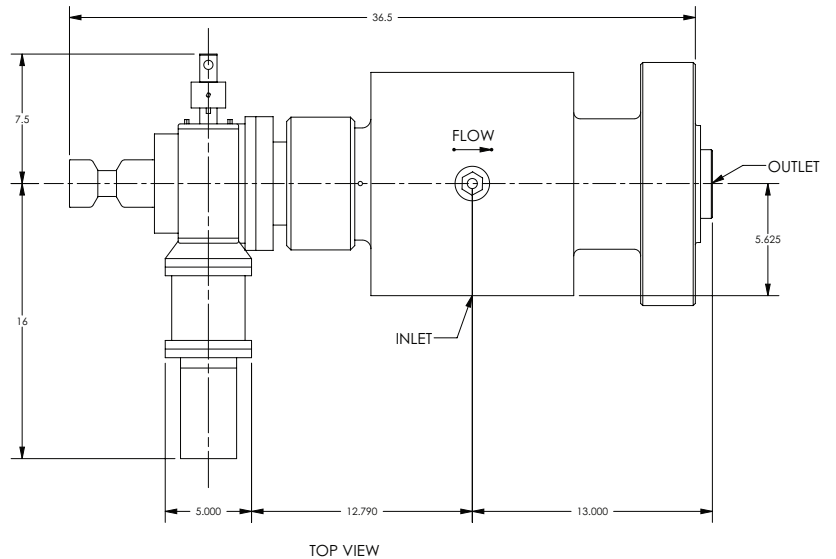
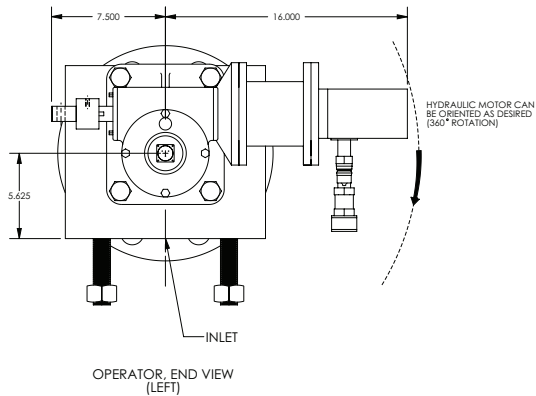

Standard Configuration

Reversible, balanced, erosion-resistant trim

Pressure Ratings Available	API 5,000; 10,000; 15,000 psi
Inlet Size Ranges	1-13/16" to 7-1/16"
Outlet Size Ranges	4-1/16" to 7-1/16"
Trim Sizes Available	1-1/2", 2" or 3"
Testing	API 6A, API 16C
Body Material	API 75K, Impact Tested IAW NACE MR01-75
Throttling Trim Material	Tungsten Carbide
Seat Material	Tungsten Carbide
Seat Leakage	Drop Tight
API Temperature Ranges	
Standard	-20°F to +250°F (-29°C to +121°C)
Optional	-75°F to +350°F (-60°C to +177°C)
API 6A PSL	1 - 3, 3G
API 6A PR	1 - 2

General Design Specifications

Maximum Open for Controllability	85%
Minimum Open for Controllability	2%
Maximum Exit Velocity	1.0 Mach
Max. Downstream Velocity (Gas)	0.3 Mach
Max. Downstream Velocity (Liquid)	100 - 200 ft/sec
Hydraulic Operating Pressure	1,800 psig
Shut Off	Drop Tight (Exceeds ANSI Class V)
Throttling Pressure Drop	Full-Rated Pressure